

GBU4005-G Thru. GBU410-G

Reverse Voltage: 50 to 1000V

Forward Current: 4.0A

RoHS Device

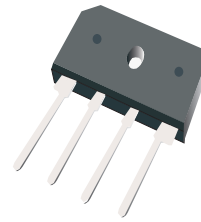

Features

- Surge overload rating -150 amperes peak.
- Ideal for printed circuit board.
- UL recognized file # E349301

Mechanical Data

- Epoxy: UL 94V-0 rate flame retardant.
- Case: Molded plastic, GBU
- Mounting position: Any
- Weight: 3.91 grams (approx.).

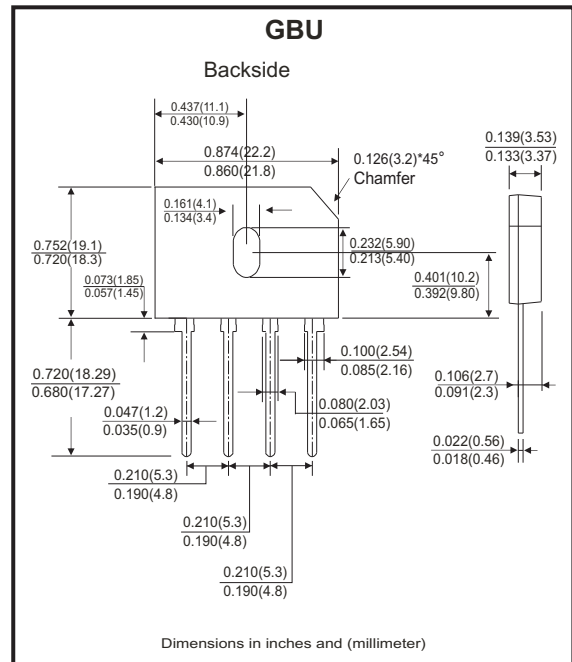

Maximum ratings and electrical characteristics

Rating at 25°C ambient temperature unless otherwise specified.
Single phase, half wave, 60Hz, resistive or inductive load.
For capacitive load, derate current by 20%

Parameter	Symbol	GBU 4005-G	GBU 401-G	GBU 402-G	GBU 404-G	GBU 406-G	GBU 408-G	GBU 410-G	Unit	
Maximum Recurrent Peak Reverse Voltage	V_{RRM}	50	100	200	400	600	800	1000	V	
Maximum RMS Voltage	V_{RMS}	35	70	140	280	420	560	700	V	
Maximum DC Blocking Voltage	V_{DC}	50	100	200	400	600	800	1000	V	
Maximum Average Forward (With heatsink Note2) Rectified Current @ $T_c=100^\circ\text{C}$ (without heatsink)	I_{AV}	4.0								A
Peak Forward Surge Current, 8.3ms Single Half Sine-Wave Super Imposed On Rated Load (JEDEC Method)	I_{FSM}	150								A
Maximum Forward Voltage at 2.0A DC	V_F	1.0								V
Maximum Forward Voltage at 4.0A DC	V_F	1.1								V
Maximum DC Reverse Current @ $T_J=25^\circ\text{C}$ At Rated DC Blocking Voltage @ $T_J=125^\circ\text{C}$	I_R	10.0								μA
I^2T Rating for Fusing ($t < 8.3\text{ms}$)	I^2t	93								A^2s
Typical Junction Capacitance Per Element (Note 1)	C_J	45								pF
Typical Thermal Resistance	$R_{\theta JC}$	2.2								$^\circ\text{C}/\text{W}$
Operating Temperature Range	T_J	-55 to +150								$^\circ\text{C}$
Storage Temperature Range	T_{STG}	-55 to +150								$^\circ\text{C}$

Notes:

1. Measured at 1.0MHz and applied reverse voltage of 4.0V DC.
2. Device mounted on 50mm*50mm*1.6mm Cu plate heatsink.

Company reserves the right to improve product design, functions and reliability without notice.

REV: D

Rating and Characteristics Curves (GBU4005-G Thru. GBU410-G)

Fig.1 - Forward Current Derating Curve

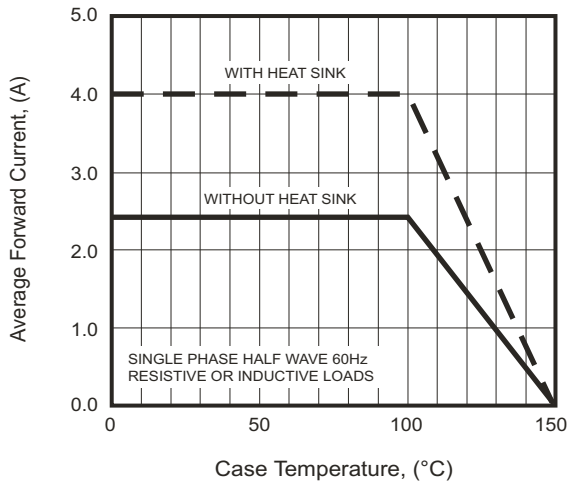

Fig.2 - Typical Forward Characteristics

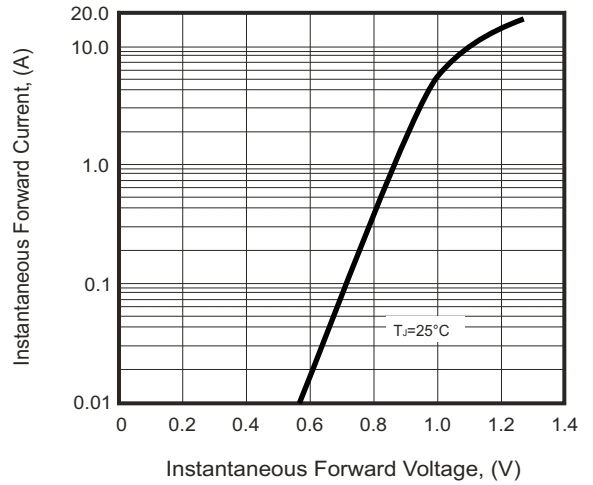

Fig.3 - Maximum Non-Repetitive Surge Current

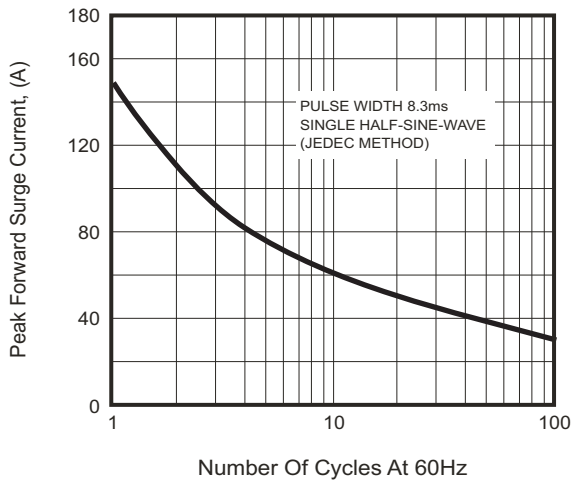

Fig.4 - Typical Junction Capacitance

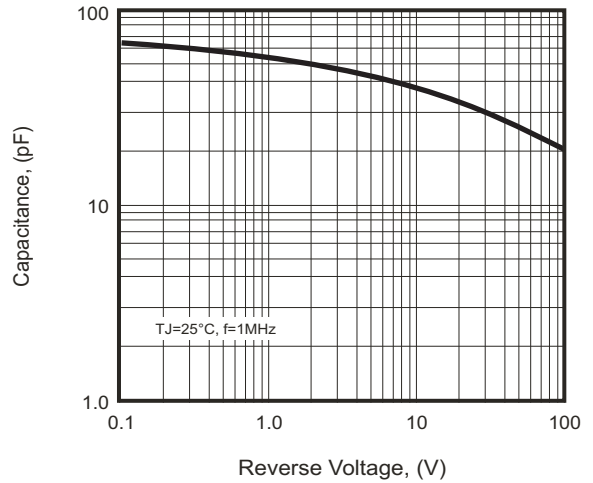
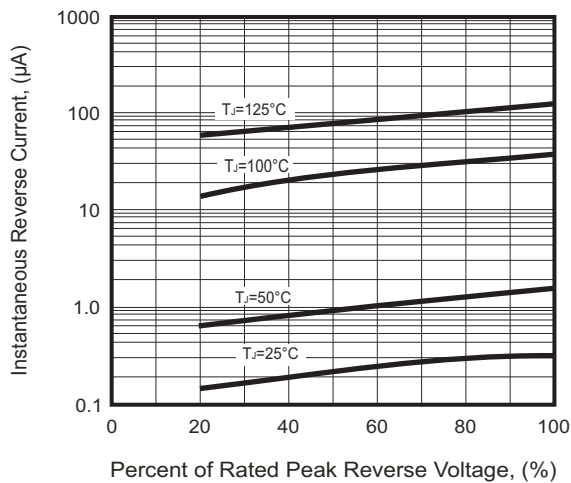

Fig.5 - Typical Reverse Characteristics



Company reserves the right to improve product design, functions and reliability without notice.

Marking Code

Part Number	Marking code
GBU4005-G	GBU4005
GBU401-G	GBU401
GBU402-G	GBU402
GBU404-G	GBU404
GBU406-G	GBU406
GBU408-G	GBU408
GBU410-G	GBU410

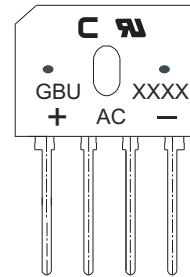

XXX / XXXX = Product type marking code
C = Compchip Logo

Standard Packaging

Case Type	TUBE PACK	
	TUBE (pcs)	Carton (pcs)
GBU	20	1,000